

# BALCONGLAS FALCINO-50

**MY METALGLAS**

€▶C.305

SISTEMA CON CANALINA / SYSTEMS WITH BOTTOM GUIDE / SYSTEM MIT BODENFÜHRUNG

- Sistema a pannelli mobili in vetro, impacchettabili senza la baia di parcheggio, con guida a terra, con profili anta con fori nel vetro.
- Slide and turn system, with floor channel and without parking bay, panels with holes in the glass.
- Schiebe-Dreh-System mit beweglichen Glasmodulen mit Glasbohrungen, mit Bodenführung und ohne Parkraum.



- Indicare sempre il verso di apertura e lo spessore vetro
- Please specify always opening direction and glass thickness
- Bitte immer Öffnungsrichtung und Glasdicke angeben

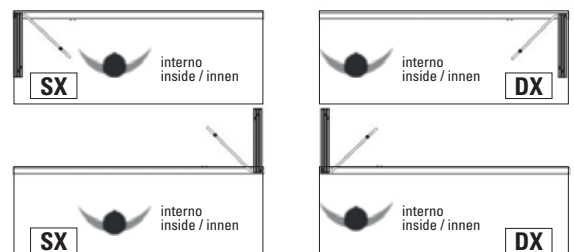

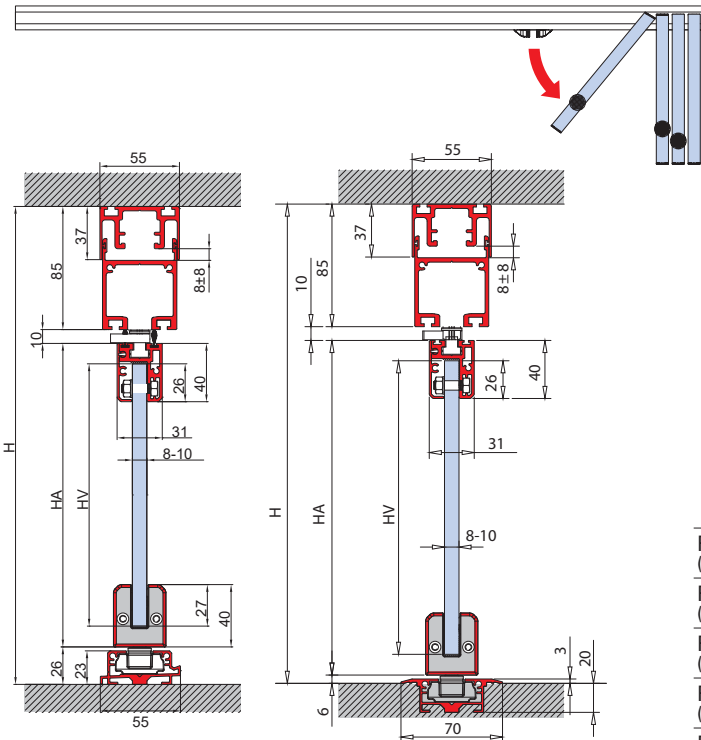
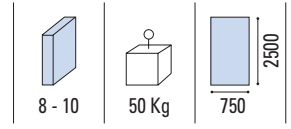
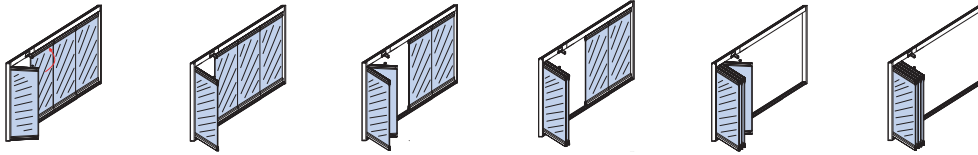

- Siliconare
- Glass to be glued
- Glas kleben

LAVORAZIONE VETRO  
GLASS PREPARATION  
GLASBEARBEITUNG

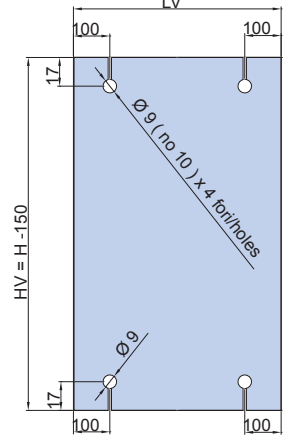

- FALCINO SET 2 (LB MAX = 1600 mm) **A C**
- FALCINO SET 3 (LB MAX = 2400 mm) **A B C**
- FALCINO SET 4 (LB MAX = 3200 mm) **A B B C**
- FALCINO SET 5 (LB MAX = 4000 mm) **A B B B C**
- FALCINO SET 6 (LB MAX = 4800 mm) **A B B B B C**
- FALCINO SET 7 (LB MAX = 5600 mm) **A B B B B B C**
- FALCINO SET 8 (LB MAX = 6400 mm) **A B B B B B B C**

- A**
  - Porta laterale
  - Pivot door
  - Seitentür
- B**
  - Anta intermedia scorrevole
  - Intermediate folding panel
  - Mittiges Faltelement
- C**
  - Ultima anta
  - Last panel
  - End-Schiebeflügel

- Canalina incassata BGM-110
- Recessed floor profile BGM-110
- Versenkte Bodenschiene BGM-110

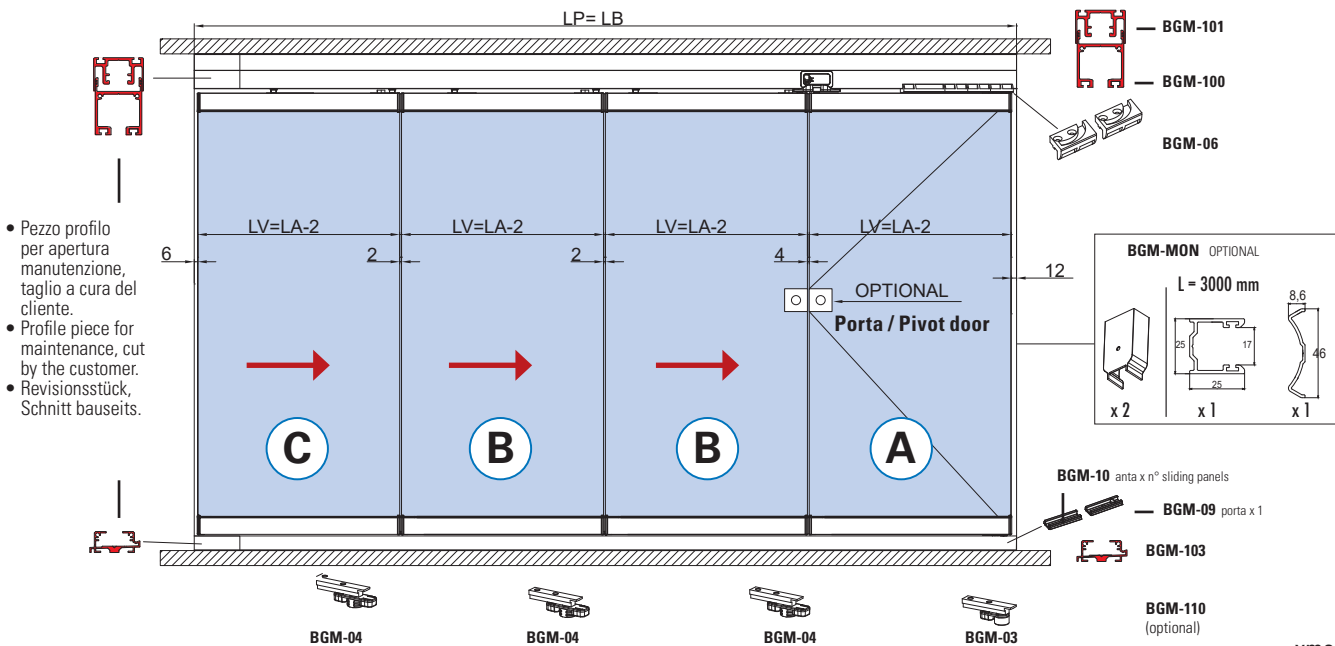
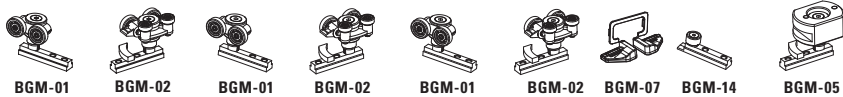

- Pezzo profilo per apertura manutenzione, taglio a cura del cliente.
- Profile piece for maintenance, cut by the customer.
- Revisionsstück, Schnitt bauseits.

- BGM-10 anta x n° sliding panels
- BGM-09 porta x 1
- BGM-103
- BGM-110 (optional)

**LP**  
Passaggio luce  
Clear opening width  
Lichte Durchgangsbreite

**LA = LV**  
Larghezza ante = Larghezza vetro  
Panel width = Glass width  
Flügelbreite = Glasbreite

**H**  
Altezza passaggio luce  
Clear opening height  
Lichte durchgangshöhe

**HV**  
Altezza vetro  
Glass height  
Glashöhe

**HA**  
Altezza anta  
Door height  
Tür Höhe

xme429

# BALCONGLAS FALCINO-50

**COME USARE MY METALGLAS / HOW TO USE MY METALGLAS / WIE MAN BENUTZT MY METALGLAS**

**1** INSERIRE LE MISURE DEL TUO VANO E LE ANTE DESIDERATE  
ENTER THE MEASUREMENTS OF YOUR OPENING AND THE DOORS YOU REQUIRE  
GEBEN SIE DIE MASSE IHRER ÖFFNUNG EIN UND DIE ERFORDERLICHEN TÜREN

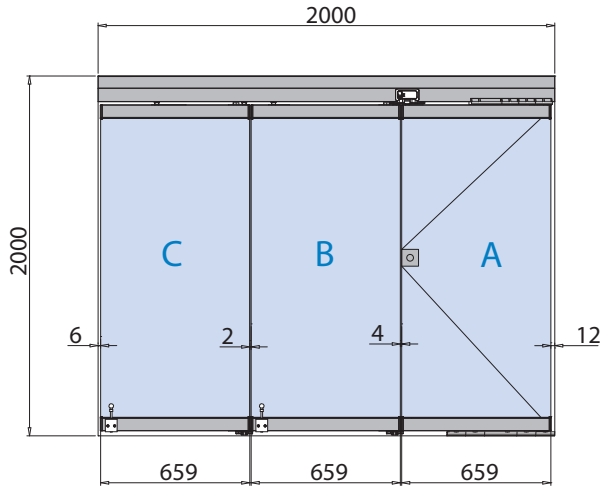

**2** SI OTTENGONO LE MISURE DEI VETRI AUTOMATICAMENTE  
THE MEASUREMENTS OF THE GLASS WILL BE GENERATED AUTOMATICALLY  
DIE ABMESSUNGEN DES GLASES WERDEN AUTOMATISCH BERECHNET

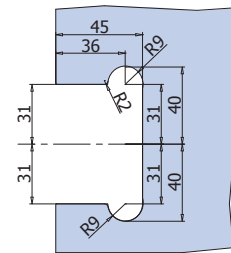
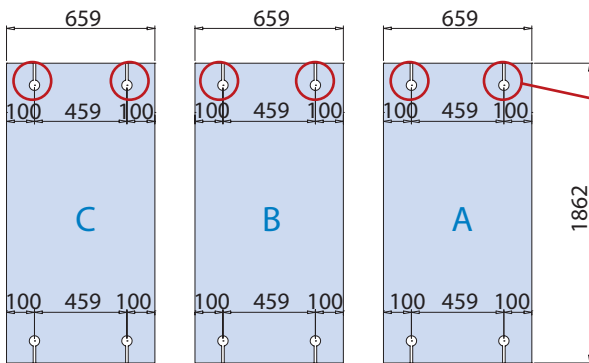

- Foratura vetro porta battente per serrature optional V-565, V-585, V-575  
Altre serrature disponibili catalogo Indoor sez. "E"
- Glass preparation pivot door for optional locks V-565, V-585, V-575. For other available locks see catalogue Indoor "E"
- Glasbearbeitung Dreh-Flügel für optionale Schlösser V-565, V-585, V-575. Für andere verfügbare Modelle siehe Katalog Indoor "E"

**3** SI OTTENGONO LE DISTINTE DI TAGLIO DEI PROFILI, DA ABBINARE AGLI ACCESSORI  
THE CUTTING SPECIFICATIONS OF THE PROFILES ARE OBTAINED, FOR MATCHING WITH THE ACCESSORIES  
SIE ERHALTEN EINE SPEZIFIKATION DER PROFILLÄNGEN ZUM ABGLEICHEN MIT DEM ZUBEHÖR

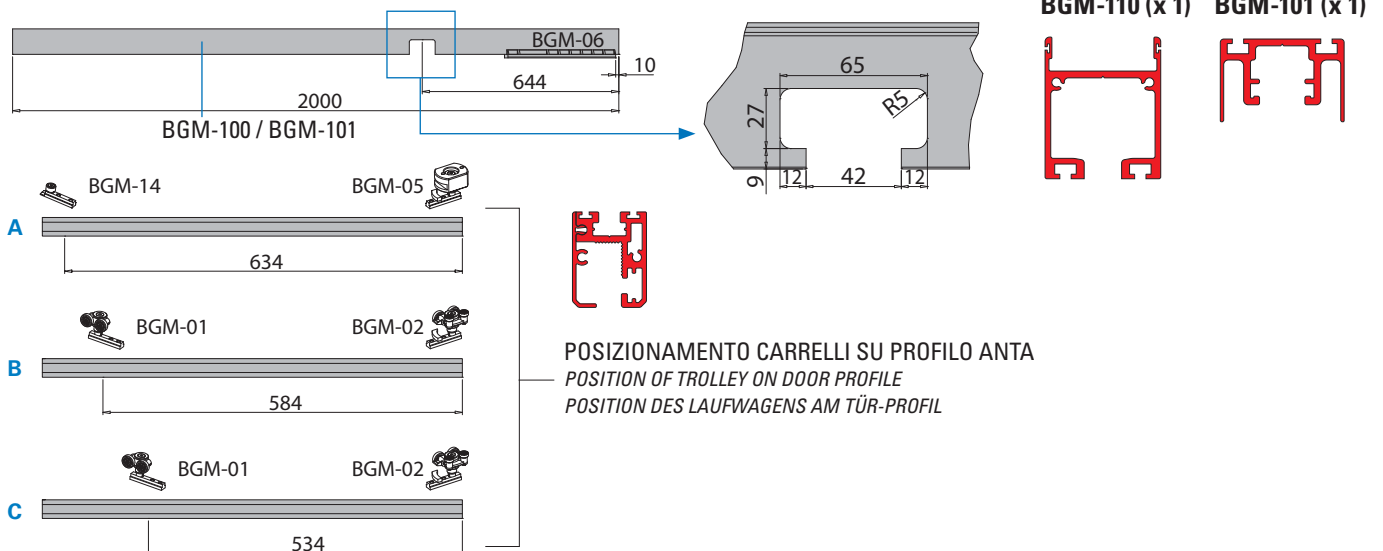

POSIZIONAMENTO CARRELLI SU PROFILO ANTA  
POSITION OF TROLLEY ON DOOR PROFILE  
POSITION DES LAUFWAGENS AM TÜR-PROFIL

# BALCONGLAS FALCINO-50

## COME ASSEMBLARE LE ANTE / HOW TO ASSEMBLE THE DOORS / WIE DIE TÜREN ZUSAMMENSETZT WERDEN

TAGLIO PROFILI PROFIL PREPARATION / PROFILBEARBEITUNG	KIT ACCESSORI ACCESSORY SETS / ZUBEHÖR SETS	ANTA COMPLETA COMPLETE DOOR / KOMPLETTE TÜR
--	--	--

**ANTA C / DOOR C / TÜRA**

**SUPERIORE / TOP / OBEN**

**INFERIORE / BOTTOM / UNTEN**

**BGM-ANTA-A-DX / BGM-ANTA-A-SX**  
 ULTIMA ANTA A  
 LAST PANEL A / ENDFLÜGEL A

**ANTA B / DOOR B / TÜRB**

**SUPERIORE / TOP / OBEN**

**INFERIORE / BOTTOM / UNTEN**

**BGM-ANTA-B-DX / BGM-ANTA-B-SX**  
 ANTA INTERMEDIA B  
 INTERMEDIATE PANEL B / MITTIGE FLÜGEL B

**ANTA A / DOOR A / TÜR C**

**SUPERIORE / TOP / OBEN**

**INFERIORE / BOTTOM / UNTEN**

**BGM-ANTA-C-DX / BGM-ANTA-C-SX**  
 PORTA LATERALE C  
 LATERAL PIVOT DOOR C / DREHFLÜGEL C